

REVISION HISTORY			
REV	DESCRIPTION	DATE	APPROVED

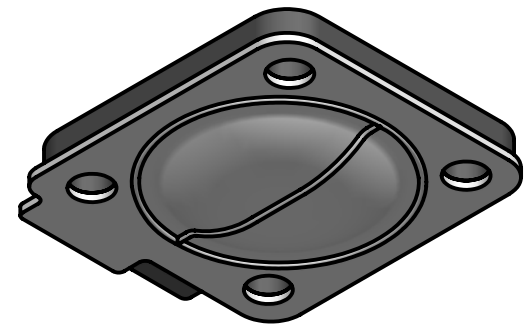
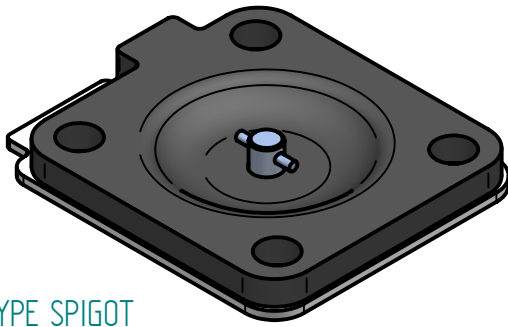

Replacement Diaphragm for :-  
 OEM PART = DA015S5  
 USED ON 1/2" (DN15,) Diaphragm Valve

	NAME	DATE	
DRAWN	M. MC KEON	02/25/15	
CHECKED			
<b>Material -</b> <b>EPDM BACKING</b> <b>TFM - DIAPHRAGM</b>			TITLE <b>DD05-STFM-C</b>
Complies with CFR 177.2600 and Conforms to USP Class VI Biological Reactivity Tests Section #87 and #88			SIZE A
			<b>FOOT PRINT DIMENSIONS</b>
			FILE NAME: DD05-STFM-C.dft
		SCALE: 1 : 1	ECO:0605 SHEET 1 OF 1

Disclaimer - Diaphragm Direct® does not manufacture, represent, nor sell OEM valves or diaphragms manufactured by any other company. Diaphragm Direct® brand diaphragms are not sponsored by any other manufacturers. Any name, model, part number, brand, image, material or referral is for descriptive purposes only. Diaphragm Direct® brand replacement diaphragms are guaranteed to fit OEM equipment and meet or exceed OEM specifications. Diaphragm Direct® brand replacement diaphragms are covered by the standard Diaphragm Direct® limited product warranty.